

T 815-7T3B31 6x6.1R



DEFENCE

6x6 HIGH MOBILITY HEAVY DUTY CHASSIS

The TATRA 6x6 High Mobility Heavy Duty (HMHD) chassis is built as a platform for various kinds of special vehicles that need:
• superior drive ability in difficult terrain • heavy armoured protection on top of the chassis • reliable chassis with low life cycle costs

Military chassis convenient for operation in the heaviest terrain and climatic conditions, in regions with extremely high and cold ambient temperatures, high humidity and in dusty environments.

The all-wheel drive chassis employs independent suspension and backbone tube frame, the unique features of the TATRA concept chassis proven more than 90 years, that allow each wheel to move independently with improved steering and maximum tire to ground contact.

3-dimensional space solid frame created by connection of backbone tube and conventional ladder frame is exceptionally rigid against torsion and bending. In addition the backbone tube frame also protects driveline shafts from transfer case to the wheels and differentials that are placed inside, against dust, moisture and outer mechanical damages (service-free design without cardan shaft torque distribution).

The unique chassis and independent suspension design give the vehicle exceptional resistance to shocks and vibrations, protects superstructures from torsion and stresses and allows to be driven fast on rough roads.

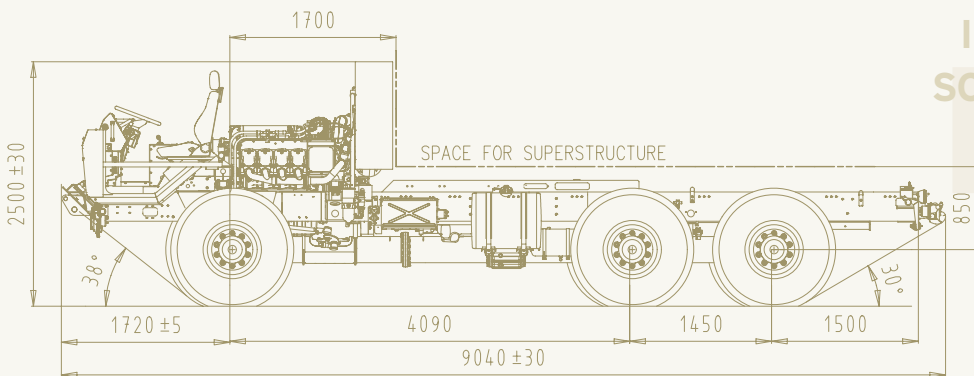

INDEPENDENT SUSPENSION
SOLID 3D STRUCTURE FRAME
18,760 kg PAYLOAD
6x6 DRIVE
300 kW

TATRA TAKES YOU FURTHER

tatratrucks.com



TATRA FORCE

T 815-7T3B31 6x6.1R

6x6 HIGH MOBILITY HEAVY DUTY CHASSIS

ENGINE TATRA T3C-928-90 EURO 3

Air cooled, four stroke turbo-charged and charge-air-cooled direct injection Diesel.

Number of cylinders	8
Bore/stroke	120/140 mm
Displacement	12.7 ltrs
Power output	300 kW/1,800 RPM
Max. torque	2,100 Nm/1,000 RPM

CLUTCH

MFZ 1x430, single plate, with diaphragm spring.
Hydraulic control with pneumatic booster.

TRANSMISSION - TATRA 14 TS 210 N

Number of speeds: - forward	14
- reverse	2

Semiautomatic split. Except of the crawler and reverse gears, all gears are synchromeshed.

TRANSFER BOX

Type TATRA 2.30 TRS 0.8/1.9. Speed reducing.
Pneumatic control.

FRONT AXLE

TATRA steered and driven swing half-axle with independent wheel suspension, axle differential lock front-drive disconnection. Wheel hub reductions.
Air springs and telescopic shock absorbers, sway bar.

REAR AXLE

TATRA driven swing half-axes with independent wheel suspension, axle differential locks and inter-axle differential lock. Wheel hub reductions.
Air springs and telescopic shock absorbers, sway bars.

STEERING

Left/right hand drive, integral power steering.

BRAKES

Wedge type self-adjustable drum brake units, ABS.
Four separate brake systems: service, emergency, parking, and engine brake.

WHEELS

Single tactical tyres on all axles with CTIS.

Rims	20 -10.00V
Tyres	14.00 R20
Run flats	
16.00R20 as option	

CAB

The chassis is delivered without standard TATRA cab. A frame holding dashboard, pedals, steering and seat is mounted on the chassis instead of the cab. Other equipments delivered as loosing parts.

Cab tilting mechanism with hydraulic cylinder controlled electrically.

ELECTRIC EQUIPMENT

Nominal voltage	24 V
Batteries	2x12V, 180 Ah
Alternators	2x120 A/28 V

DIMENSIONS

Width	2,500 mm
Track - front/rear	2,072 mm
Clearance	380 mm

Clearance can be temporarily raised/lowered by suspension on the fly.

WEIGHTS

Curb weight	10,240 kg
Payload max.	18,760 kg
GVW max.	29,000 kg

PERFORMANCE

Top speed	110 km/h
Gradeability at GVW	60 %
Side slope	45 %
Turning circle diameter (curb to curb)	20±1 m
Fording capability	1,200 mm
Crossing ability - trench width	900 mm
Fuel tank	220 ltrs
Cruising range (on road) cca	500 km
Climbing ability - vertical step	500 mm
Operating ambient temperature	-32°C to +49°C

WINCH

Optional self recovery winch, 100 kN max pulling force, 60 m rope length, front and rear rope pull.

tatratrucks.com



TATRA EXPORT s.r.o.

Areál Tatra 1450/1, 742 21 Kopřivnice, Czech Republic

tel.: +420 556 492 654, fax: +420 556 492 672, e-mail: defence@tatra.cz